

THREAD PROFILE 90-V-084 - 1.25 TAPER

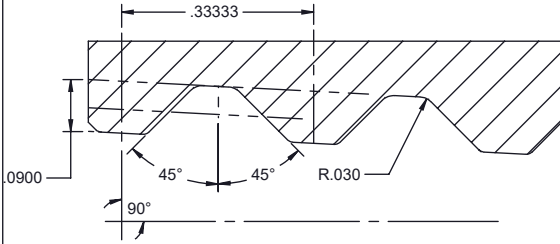

PITCH: 3.0 THREADS PER INCH (.33333 LEAD)
LEAD TOLERANCE: ±.0015 PER INCH
TAPER: 1.25 TAPER PER FT. (0.1042 in/in)

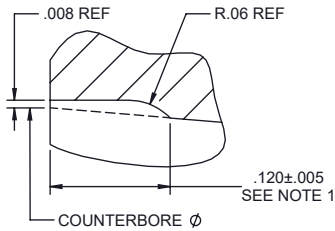

**BENCHMARK
DETAIL**

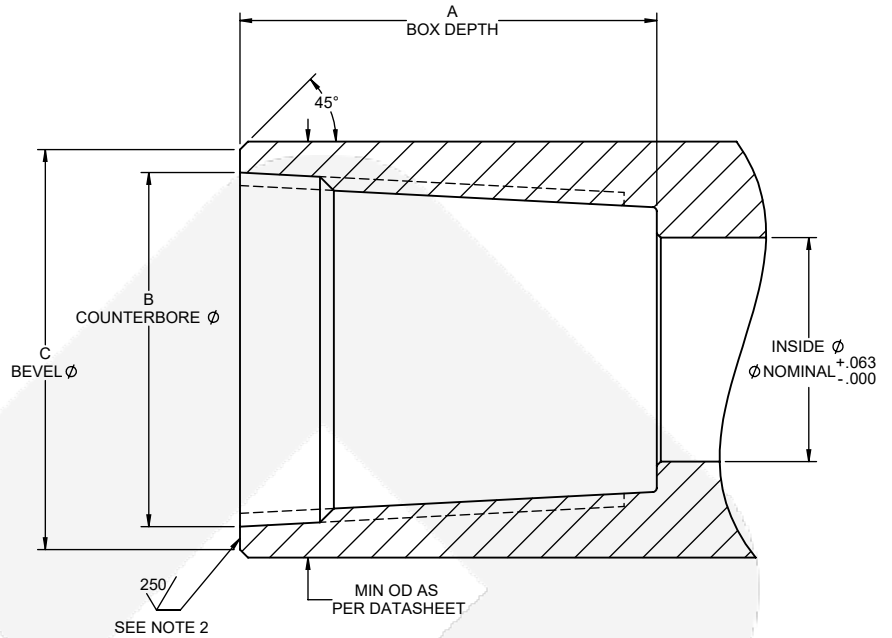

SLH90 DS BOX FIELD INSPECTION DIMENSIONS

CONNECTION	A BOX DEPTH		B C'BORE DIA.	C BEVEL DIA.
	MIN	MAX	+ .032 - .032	+ .141 - .016
2.375 SLH90 DS	3.250	3.261	2.766	3.125

NOTES:

- .125 IS FOR NEW CONDITION, MAY BE .063 MIN AFTER REFACING
- SURFACE FINISH APPLIES DURING REFACING OPERATIONS

REV.	DESCRIPTION	DATE	REV. BY
REVISIONS			

CONFIDENTIAL
 THIS DRAWING AND DATA CONTAIN PROPRIETARY INFORMATION WHICH IS CONFIDENTIAL PROPERTY OF COMPLETE GROUP LTD. AND SHALL NOT BE COPIED, REPRODUCED, DISCLOSED TO OTHERS, OR USED IN WHOLE OR IN PART FOR ANY PURPOSE WITHOUT EXPRESS WRITTEN PERMISSION. THIS DRAWING IS LOANED IN CONFIDENCE WITH UNDERSTANDING THAT IT SHALL BE RETURNED ON DEMAND.

3912 70 Avenue
Leduc AB T9E 0W1
www.completegroup.com

TITLE			
SLH90 DS BOX FIELD INSPECTION DIMENSIONS			
DRAWN	CHECKED	DRAWING #	REV
LL		T000315	0
APR 28/22		SHEET: 1 OF 1	