

**THREAD PROFILE** V-038R - MULTI TAPER

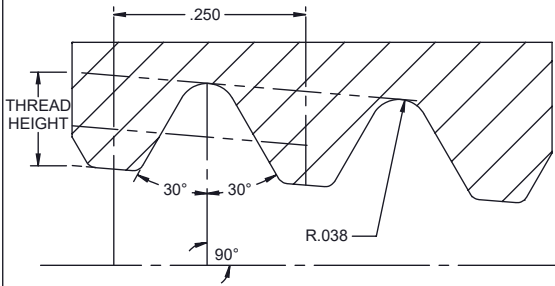

**THREAD HEIGHT** 0.75TPF - 0.1155 , 2.00TPF - 0.1218

PITCH	LEAD TOLERANCE	TAPER
4 THREADS PER INCH (.250 LEAD)	+ .003 PER 1 INCH SEE NOTE 5	2.00 TAPER PER FT. (.0625 in/in) 0.75 TAPER PER FT. (.1667 in/in)

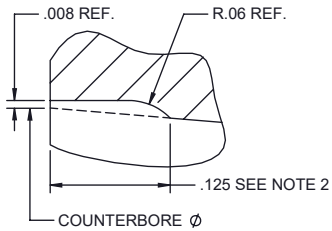

**BENCHMARK  
DETAIL**

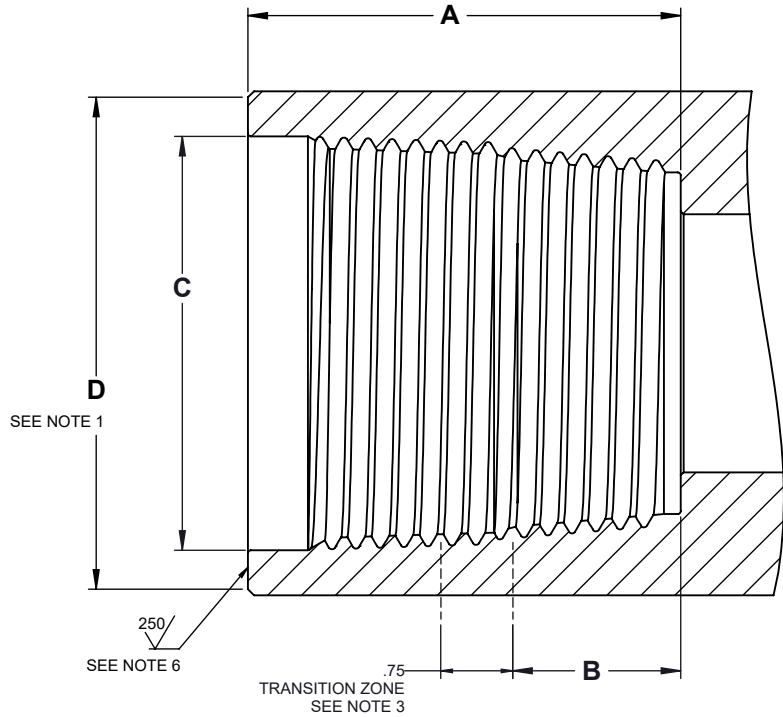

**DUO BOX FIELD INSPECTION DIMENSIONS**

CONNECTION	A BOX DEPTH		B TRANSITION LOCATION	C C' BORE		D BEVEL DIA.	TRANSITION TOOL
	MIN	MAX		+ .031 - .015	±.015		
390 DUO	4.502	4.512	1.75	4.077	4.750	D001260 - 4.5L	
400 DUO	4.494	4.506	1.75	4.311	5.125	D001260 - 4.5L	
430 DUO	4.494	4.506	1.75	4.418	5.125	D001260 - 4.5L	
450 DUO	4.494	4.506	1.75	4.604	5.250	D001260 - 4.5L	
480 DUO	4.494	4.506	1.75	4.988	5.500	D001260 - 4.5L	
530 DUO	5.002	5.008	2.00	5.446	6.375	D001260 - 5.0L	
550 DUO	5.002	5.008	2.00	5.608	6.438	D001260 - 5.0L	
580 DUO	5.002	5.008	2.00	5.931	6.750	D001260 - 5.0L	

**NOTES:**

1. MINIMUM OD = SMALLEST BEVEL DIAMETER, 1/32" X 45° CHAMFER BECOMES EFFECTIVE
2. .125 IS FOR NEW CONDITION, MAY BE .063 MIN AFTER REFACING
3. DAMAGE TO TRANSITION ZONE THREAD CRESTS AND THREAD FLANKS TO BE FIELD DRESSED AND/OR REPAIRED
4. TRANSITION ZONE MAY BE IDENTIFIED BY DIRECT MEASUREMENT OR USING TRANSITION ZONE TOOL
5. THREAD PROFILES MAY BE INSPECTED USING D001001 - DUO-01 THREAD PROFILE GAUGE
6. SURFACE FINISH APPLIES DURING REFACING OPERATIONS
7. EQUAL MATERIAL TO BE REMOVED FROM PRIMARY AND SECONDARY SHOULDERS DURING REFACING OPERATIONS.

8	REMOVE REFERENCE TO TYPE#2 AND 480-2 BEVELS, ADD 530, 580 DUO TO TABLE, REMOVE WALL THICKNESS FROM TABLE, REVISE NOTE 1 REGARDING MINIMUM OD	6/1/2026	DWD
7	CHANGE TO DDP BRANDING, REVISE DWG# FOR THREAD PROFILE GAUGE REFERENCE	4/14/2026	DWD
6	REVISED BOX LENGTH TOLERANCE 450 AND 450 TYPE #2, CHANGE LOGO	1/19/2026	DWD
REV.	DESCRIPTION	DATE	REV. BY

REVISIONS

**CONFIDENTIAL**  
THIS DRAWING AND DATA CONTAIN PROPRIETARY INFORMATION WHICH IS CONFIDENTIAL PROPERTY OF DUO DRILL PIPE, AND SHALL NOT BE COPIED, REPRODUCED, DISCLOSED TO OTHERS, OR USED IN WHOLE OR IN PART FOR ANY PURPOSE WITHOUT EXPRESS WRITTEN PERMISSION. THIS DRAWING IS LOANED IN CONFIDENCE WITH UNDERSTANDING THAT IT SHALL BE RETURNED ON DEMAND.



TITLE  
**DUO BOX FIELD INSPECTION  
DIMENSIONS**

DRAWN	CHECKED	DRAWING #	REV
SC	---	T000285	8
OCT 24/18	---	SHEET: 1 OF 1	